



WHITE-RODGERS

Type 36C04, 36C14

Step-Opening
Combination Gas Control
(24 Volt, 120 Volt & 750 mV Models)
INSTALLATION INSTRUCTIONS

Operator: Save these instructions for future use!

FAILURE TO READ AND FOLLOW ALL INSTRUCTIONS CAREFULLY BEFORE INSTALLING OR OPERATING THIS CONTROL COULD CAUSE PERSONAL INJURY AND/OR PROPERTY DAMAGE.

DESCRIPTION

This multi-function gas control combines, into a single compact package, the functions of a 3-position manual valve, a main gas valve, pressure regulator and 100% shut-off automatic pilot. The pilot gas outlet accepts a 1/4" pilot line connection.

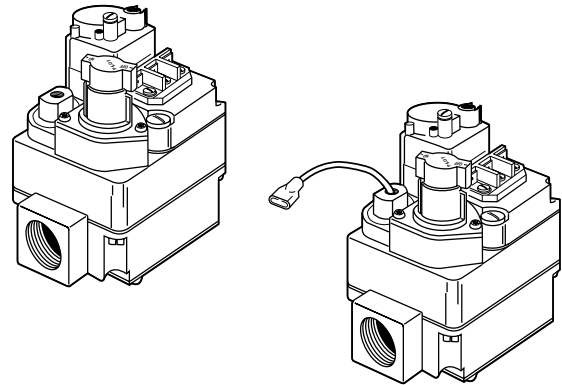

Model No.	Voltage	Type of Gas
36C04	24 Volt	Nat
36C04A	120 Volt	Nat
36C04U	750 mV	Nat
36C14	24 Volt	LP
36C14A	120 Volt	LP
36C14U	750 mV	LP

SPECIFICATIONS

Pilot Gas Outlet:

Located at outlet end of the valve

Type of Gas:

Suitable for all domestic heating gases

Pressure Rating: 1/2 lb. per sq. in.

Pressure Regulator Adjust Range (typical; see control label):

Natural Gas: 2.5 to 5.0" W.C.

LP Gas: 7.5 to 12" W.C.

Ambient Temperature: -40° to 175°F

Thermocouple (24 Volt and 120 Volt types):

Use W-R Type H06

Pilot Generator (750 mV types):

Use W-R Type G01A-32

Mounting: Any position except upside down

PIPE SIZES/CAPACITIES

Pipe Size (inches)	Capacity (BTU/hr) at 1" pressure drop across valve	
	Nat. Gas (1000 BTU/cu. ft., 64 Sp. Gr.)	LP Gas (2500 BTU/cu. ft., 1.53 Sp. Gr.)
1/2" x 3/8"	100,000	162,000
1/2" x 1/2"	230,000	372,600
1/2" x 3/4"	230,000	372,600
3/4" x 3/4"	280,000	453,600

Upright, 90° from upright or vertical

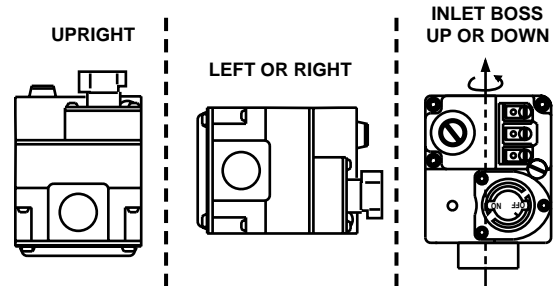

NOTE: Control shown may not be identical to replacement control.

Figure 1. Mounting positions



WHITE-RODGERS DIVISION
EMERSON ELECTRIC CO.
9797 REAVIS ROAD
ST. LOUIS, MISSOURI 63123-5398

Printed in U.S.A.

PART NO. 37-5837B
Replaces 37-5837A
9947

PRECAUTIONS

DO NOT BEGIN INSTALLATION UNTIL YOU READ THE FOLLOWING PRECAUTIONS.

⚠ WARNING



If you do not follow these instructions exactly, a fire or explosion may result, causing property damage, personal injury or loss of life.

1. Failure to turn off electric or main gas supply to heating system could cause personal injury and/or property damage by shock, gas suffocation, fire, and/or explosion.
2. Do not use this control on circuits exceeding specified voltage. Higher voltage will damage the control and may cause shock or fire hazard.
3. **NEVER USE FLAME OR ANY KIND OF SPARK TO CHECK FOR GAS LEAKS—COULD CAUSE FIRE AND/OR EXPLOSION.**
4. **DO NOT USE WIRE JUMPER** on pilot systems, such as standing pilot, proven pilot, or spark-to-pilot ignition—a fire and/or explosion may result.
5. Do not use a control set for natural gas with LP gas, or a control set for LP gas with natural gas. Personal injury and/or property damage, gas suffocation, fire, and/or explosion may result.

⚠ CAUTION

1. Do not short out terminals on gas valve or primary control to test. Short or incorrect wiring can cause equipment damage, property damage, and/or personal injury.
2. This control is not intended for use in locations where it may come in direct contact with water. Suitable protection must be provided to shield the control from exposure to water (dripping, spraying, rain, etc.).

INSTALLATION

MAIN PIPING CONNECTIONS

NOTE

All piping must comply with local codes, ordinances, and/or national fuel gas codes.

1. Turn off electrical power to the system at the fuse box or circuit breaker. Also turn off the main gas supply.
2. If replacing an existing valve, disconnect all plumbing and electrical connections from the old control.
3. The valve may be installed in any position **except upside down**. The arrow on the bottom plate indicates the direction of gas flow through the valve.
4. You should use new pipe that is properly chamfered, reamed, and free of burrs and chips. If you are using old pipe, be sure it is clean and free of rust, scale, burrs, chips, and old pipe joint compound.
5. Apply pipe joint compound (pipe dope) or teflon tape that is approved for all gases, only to the male

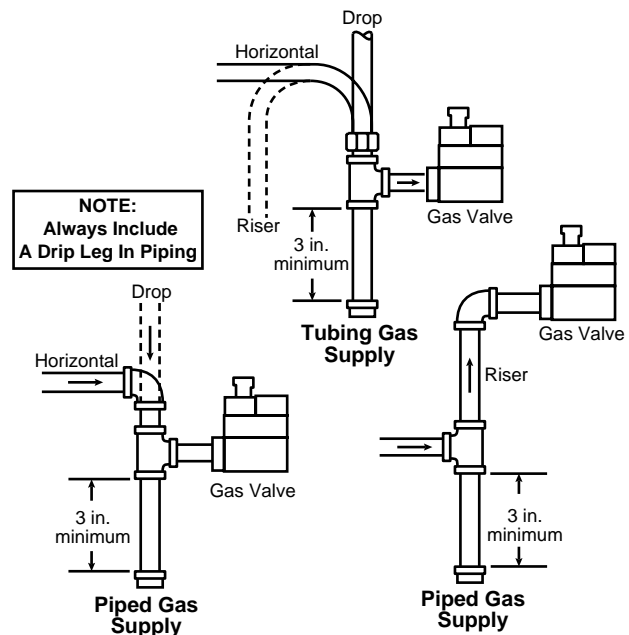

Figure 2. Typical gas valve piping

threads of the pipe joints. **DO NOT** apply compound or teflon tape to the first two threads (see fig. 2 for typical piping connections).

6. If you are using a vise or open-end wrench to hold the valve while installing piping, do not tighten excessively, as this may damage the valve.
7. See **SYSTEM WIRING** when making electrical connections. After all gas and electrical connections are completed, turn gas on and check for gas leaks with leak detection solution or soap suds. Bubbles forming indicate a leak. **SHUT OFF GAS AND FIX ALL LEAKS IMMEDIATELY.**

PILOT GAS CONNECTION

Install fitting into pilot gas outlet (see fig. 3), turning until finger-tight. Insert clean, deburred tubing all the way through the fitting. While holding the tubing securely, slowly tighten fitting until you feel a slight "give". Tighten the fitting an additional 1½ turns

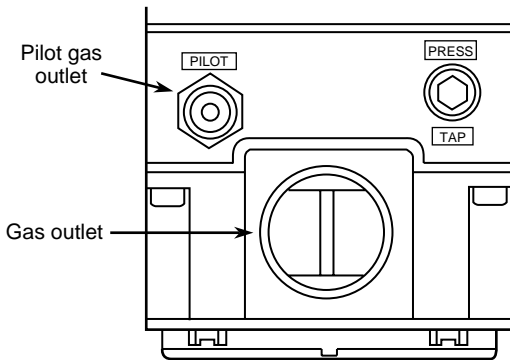

Figure 3. Gas valve side view

SYSTEM WIRING

NOTE

REFER TO AND FOLLOW THE APPLIANCE MANUFACTURER'S WIRING DIAGRAM. REFER TO FIGS. 4 & 5 FOR TERMINAL IDENTIFICATION.

All wiring should be installed in accordance with local and national electrical codes and ordinances.

Always check that the electrical power supply used agrees with the voltage and frequency shown on the gas control.

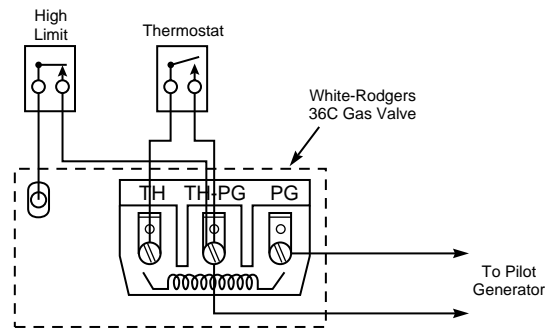

Figure 4. Wiring for 36C04U & 36C14U (.750 Volt)

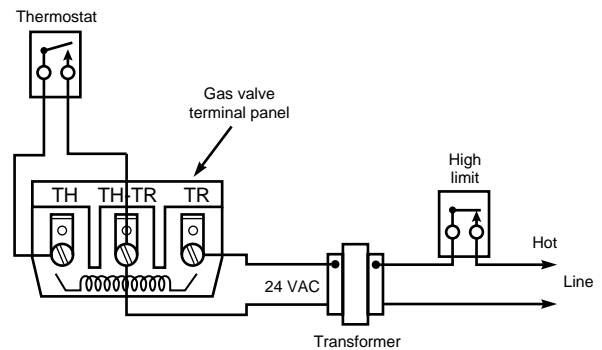

Figure 5. Wiring for 36C04 & 36C14 (24 Volt)

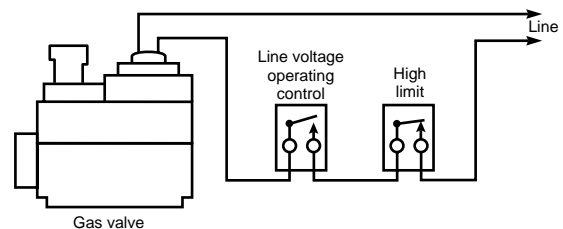

Figure 6. Wiring for 36C04A & 36C14A (120 Volt)

ADJUSTMENT

THERMOCOUPLE CONNECTION (For 24 VAC and 120 VAC Models)

The thermocouple connection should be clean to ensure good electrical contact. Run the thermocouple nut into the power unit tapping as far as possible by hand. Then use a small wrench to set the nut with a $\frac{1}{4}$ to $\frac{1}{2}$ additional turn. **Do not overtighten.**

PILOT GENERATOR CONNECTION (For 750 mV Models)

Be sure the pilot generator is completely engaged into the pilot burner. Be sure that the two terminals from the pilot generator are securely tightened beneath the proper screws on the valve. Connect the power unit lead to the high limit and the high limit to the TH-PG terminal.

PILOT GAS ADJUSTMENT

If the pilot flame is low and does not engulf the bulb of the mercury flame sensor, the system will not energize the main valve. If pilot gas pressure is too high, gas will sputter past the ignition electrode, and may not ignite. High pilot gas pressure may also cause the flame to lift off the burner, causing the flame sensor bulb to sense "low" heat.

To adjust the pilot gas pressure, remove the cover screw (see fig. 7). **To REDUCE pilot pressure**, turn the pilot adjust screw (beneath the cover screw) clockwise (↻). **To INCREASE pilot pressure**, turn the pilot adjust screw counterclockwise (↺). Replace and tighten cover screw.

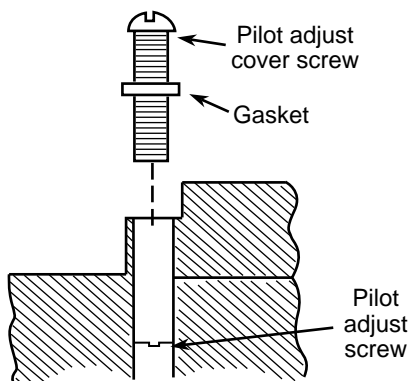

Figure 7. Pilot flame adjustment

PRESSURE REGULATOR ADJUSTMENT

This valve is shipped from the factory with the regulator adjusted for 3.5" (natural gas). Consult the appliance rating plate to ensure that this is the proper burner manifold pressure. If another outlet pressure is required, adjustment can be made as follows. **Do not force the adjusting screw beyond the limits that it can easily be adjusted.**

1. Turn off power to system at main fuse or circuit breaker.
2. Attach a manometer to the outlet pressure tap of the gas valve.
3. Turn on power to the system and energize second stage system to ignite main burner.
4. Remove plug from hole in plastic cover on top of control panel.
5. **To DECREASE outlet pressure**, turn the adjusting screw (beneath the plug) counterclockwise (↺). **To INCREASE outlet pressure**, turn the adjusting screw clockwise (↻). Adjust regulator until pressure shown on manometer matches the pressure specified on the appliance rating plate.
6. Replace the plug. Cycle the valve two or three times to verify regulator setting.

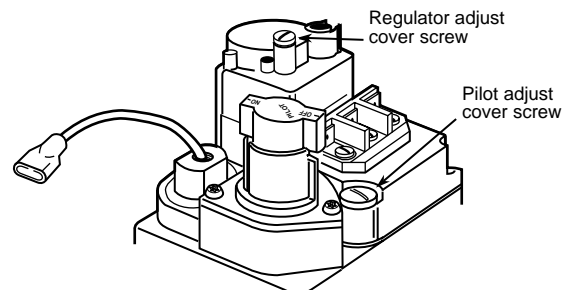

Figure 8. Gas valve top

PILOT LIGHTING INSTRUCTIONS AND PRECAUTIONS

FOR YOUR SAFETY READ BEFORE LIGHTING

⚠ WARNING



If you do not follow these instructions exactly, a fire or explosion may result causing property damage, personal injury or loss of life.

- A. This appliance has a pilot that must be lighted by hand. When lighting the pilot, follow these instructions exactly.
- B. **BEFORE LIGHTING**, smell all around the appliance area for gas. Be sure to smell next to the floor because some gas is heavier than air and will settle on the floor.

FOR YOUR SAFETY "WHAT TO DO IF YOU SMELL GAS"

- Do not try to light any appliance.
- Do not touch any electrical switch; do not use any phone in your building.
- Immediately call your gas supplier from a neighbor's phone. Follow the gas supplier's instructions.

- If you cannot reach your gas supplier, call the fire department.
- C. Use only your hand to push in or turn the gas control knob. **Never use tools.** If the knob will not push in or turn by hand, don't try to repair it; call a qualified service technician. Force or attempted repair may result in a fire or explosion.
- D. Do not use this appliance if any part has been under water. Immediately call a qualified service technician to inspect the appliance and to replace any part of the control system and any gas control that has been under water.

LIGHTING INSTRUCTIONS

1. **STOP!** Read the precautionary information above.
2. Set the thermostat to lowest setting.
3. Turn off all electrical power to the appliance.
4. Depress gas control knob slightly and turn clockwise to **OFF** (see fig. 6). If knob is in **ON**, turn clockwise to **PILOT**, then depress knob slightly and turn clockwise to **OFF**.

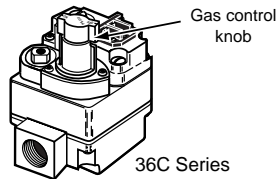

NOTE: Knob cannot be turned from **PILOT** to **OFF** unless knob is depressed slightly. Do not use tools or excessive force.

5. Wait five (5) minutes to clear out any gas. If you then smell gas, **STOP!** Follow **B** in the precautionary information above. If you don't smell gas, go to next step.
6. Remove the pilot access panel(s) located under the gas control unit.

7. Find pilot - follow small metal tubes from gas control.

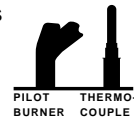

8. Turn knob on gas control counterclockwise to **PILOT**.
9. Depress control knob all the way and hold in. **Immediately** light the pilot with a match. Continue to hold the control knob down for about one (1) minute after the pilot is lit. Release knob and it will pop back up. Pilot should remain lit. If it goes out, repeat steps 4, 5, 8, and 9.
- If knob does not pop up when released, turn clockwise to **OFF**, stop and immediately call your service technician or gas supplier.
- If the pilot will not stay lit after several tries, turn the gas control knob to **OFF** and call your service technician or gas supplier.
10. Replace pilot access panel(s).
11. Turn gas control knob counterclockwise to **ON**.
12. Turn on all electrical power to the appliance.
13. Set thermostat to desired setting.

TO TURN OFF GAS TO APPLIANCE

1. Set the thermostat to lowest setting.
2. Turn off all electrical power to the appliance if service is to be performed.
3. Turn gas control knob clockwise to **PILOT**.
4. Depress gas control knob slightly and turn clockwise to **OFF**. **Do not use tools or excessive force.**

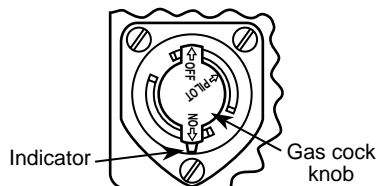

Figure 9. Gas cock knob

If you need more information about this product, please write to us at:

WHITE-RODGERS DIVISION, Emerson Electric Co.
9797 Reavis Road
St. Louis, MO 63123-5398
Attn: Technical Service Department